

Raised Floor System



METHOD
OF INSTALLATION

CONTENTS

	<u>Subject</u>	<u>Page No.</u>
1.	Introduction	3
2.	Components	4
3.	Storage	5
4.	Pre Installation Jobs	5
5.	Site Preparation	5
6.	Tools & Safety Items	5
7.	Installation Procedure	6 -10
8.	Perimeter cut panels	11
9.	Wiring & Connections	12-14

Introduction

Method of raised floor installation varies in various applications. In a normal office setup where the finish floor height (FFH) is below 300mm, a stringer less installation is possible. For datacenters and equipment rooms with more loading capacity, a stringer system is recommended. When the floor height need to achieve height of 1 meter and more, heavy duty stringer based pedestal system to be installed. More over brazing also required for high floor condition.

Components

Panels

Cementitious Panel

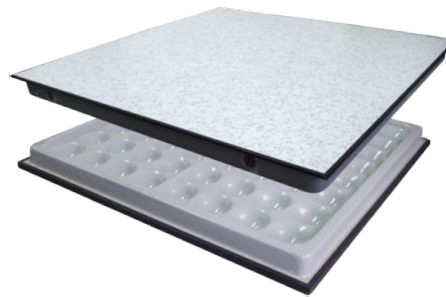

Pedestals

: `Uhi< YUX'DYXYgHJ



Stringers

6 cl `mdY'gff]b[Yf



AirFlowPanel

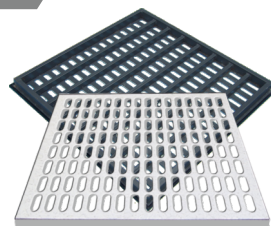

Air Flow Tile HPL/Vinyl (40%)
Top & Bottom View

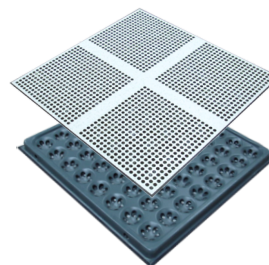

Air Flow Tile HPL/Vinyl (20%)
Top & Bottom View

Ramp

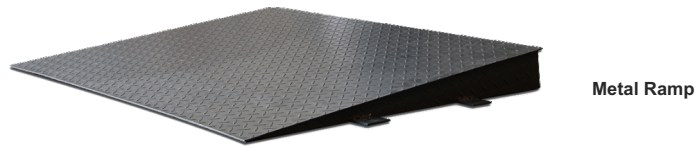

Step

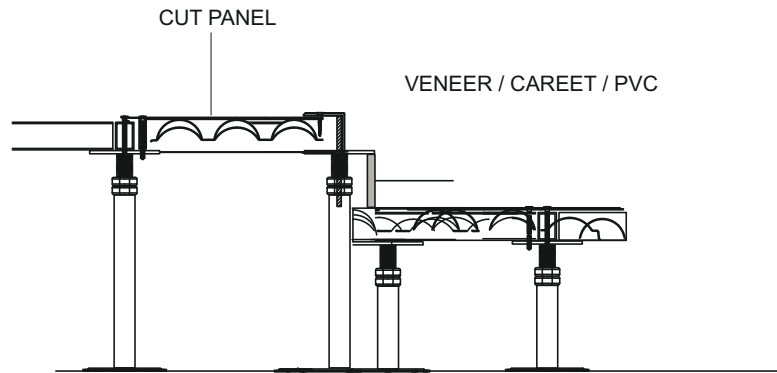

Fascia

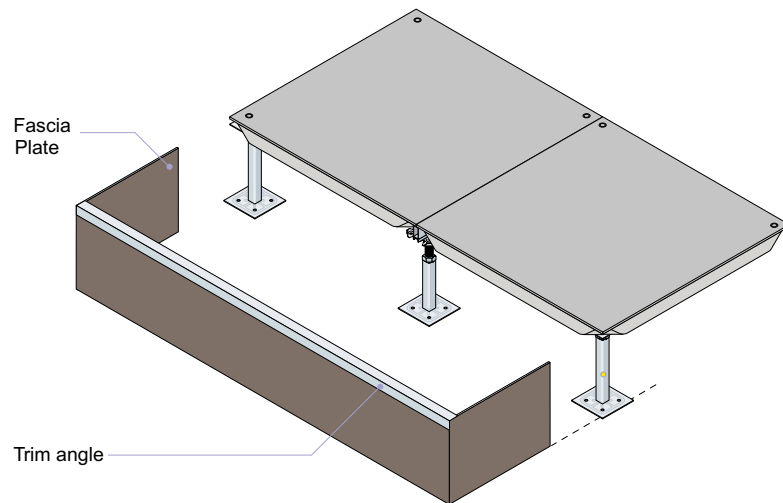

Grommet



Square Brush Grommet



Circular Brush Grommet

Screw & Panel Lifter



Panel Lifter 2 Jaws



Screws

Storage

Once the materials are delivered to the site, it should be stored in a clean and dry place. The storage place should not allow direct sunlight and rain. It is better to find out a place near to installation room for the easy transport of materials to the installation area. If the installation required in a high raise building the material should be transported either by crane or by using service lifts. Proper attention is required at the time of offloading and vertical movement as it can damage the edges of tiles by hitting some hard material like fork lift or similar. As these tiles and accessories are heavy proper attention is required at all times.

Pre Installation Jobs

Make sure that all pre-installation jobs are completed and site is ready for Raised Floor installation. The following jobs need to be coordinated before installation of Raised Floor.

Anti-dust painting: Treat with a semi-mat, high-resistance, anti dust paint. This Paint will be applied in one or two layers according to the Manufacturers Instruction which should be compatible with glue used for installation of Pedestals. Ensure this job is completed as it cannot be done after installation.

Trunking installation : Proper coordination is required here else there will be collision in both works.

Cool Air duct works : Height of flooring and air opening need to arrange accordingly.

Ceiling Works : This has to be finished before starting Raised Floor work. Sometimes installation team needs to do the site marking of pedestals prior to the installation to complete the related works like trunking and duct installation.

Site Preparation

- Condition of subfloor (clean and dry)
- Finish floor height
- Cut piece location
- Conflict with any other works (work schedule of other works)
- Proximity to store
- Light and power availability
- Accessibility
- Work timing

Tools and Safety Items

Tools required for Installation:.. Infrared ray level instrument, large push cutter, aluminum alloy ruler, level bar, electric hand drill, Mini type Marble cutter, pulling nail gun, wire cutter, steel ruler, nail, pencil, suction disc machine, hammer, spanner, screwdriver, floor glue, tool bag, broom.

Proceed with installation of access flooring system only after the completion of other construction within affected areas. A team of 4 workers and one foreman who has the ability to communicate and strengthen his team as per site construction.

Installation of Systems

Compare raised floor drawing with the site conditions to plan the cut tiles area as discussed and agreed with the contractor, if there is no prior agreement start installing from the centre of the room or any one side of the room in such a way that the installation should not hit any object on the subfloor and cut tiles should not be less than 15cm.

Determining Pedestal Height

Check the height of the Raised Floor in the drawing and actual height required as per the door level or any particular reference level marked, any variation in both levels need to be cleared before starting installation.

Once the height and starting point is fixed make a control line manually or by using the laser level machine to get the control level of installation of pedestals.

In the stringer system pedestal height should be less than finish floor height (ffh) as the height of the stringer also determines the ffh. In this case of the stringer system where the stringer is fixed on the pedestal provides no extra length, the thickness of the tile need to be calculated to determine the FFH.

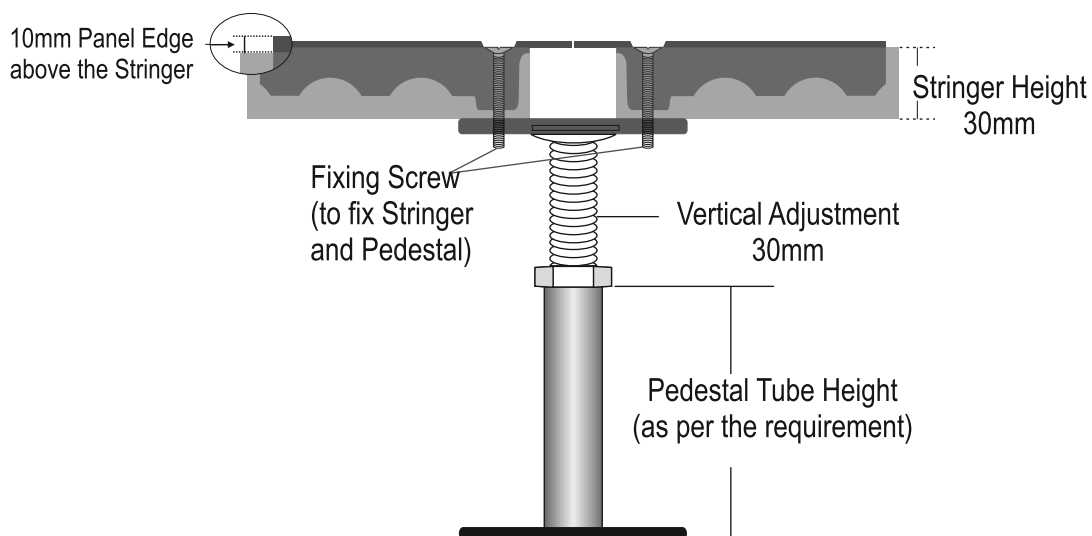

Structure of Cementitious

Tracing the Floor Modulation

Before the assembly of the raised flooring, the person in charge of installation will draw the required pattern on the subfloor, in order to facilitate the installation of conduits, pipes, etc... Contractors in charge of technical utilities must take this pattern into account, so that no conduits or pipes are placed where the pedestals of the raised flooring must be installed.

Installation works under the raised flooring must be completed and performed in coordination with approved installation diagram by the Technical Dept. Using a laser, check the room dimensions, difference in the level of the slab and to locate the correct starting points of the installation. Since, the standard pedestals height adjustable is 20-50mm but often the slabs present greater differences in level.

Find the starting point in the room as shown on the drawings. Seek approval to change the starting point if cut panels at the perimeter will be too small to allow proper support. Recommended minimum size of the cut panels for proper support is 6 inches wide.

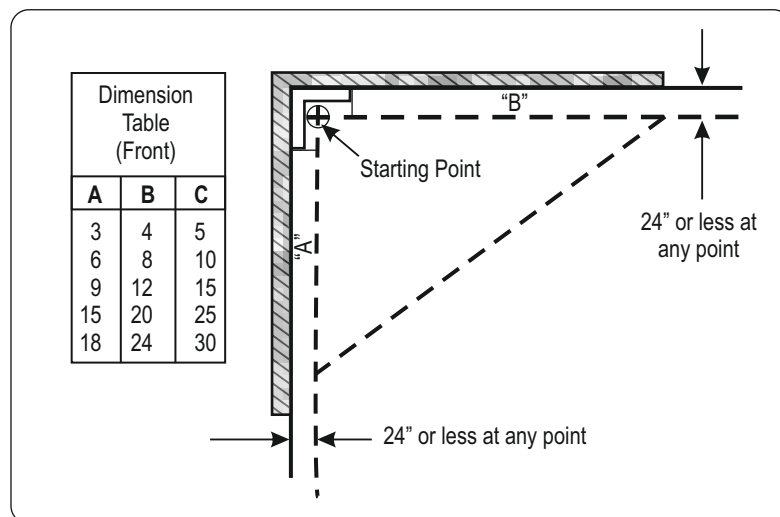

Figure 1

Marking the floor out

In a first stage, per premise, two rows of full tiles should be placed at right angles. Make sure that these rows are not placed against the walls. These floors should be placed with great precision and at the desired height. The remaining spaces against the walls will be adapted according to the measurements and fitted out after the central surface has been completely covered.

NOTE: When starting the installation in the corner of a room, stretch a dry line for line "B" before laying down chalk. Check the distance from "B" line and the "A" chalk line to the walls. If the distance to the walls is over 24 inches (600mm) at any point, move the entire line closer to the wall so that the greatest distance is 24 inches (600mm) or less (See figure 1.)

Chalk the two control lines and spread pedestal assemblies in an area approximately 48 feet x 24 feet, making sure to start at the approved starting point. (See figure 2.)

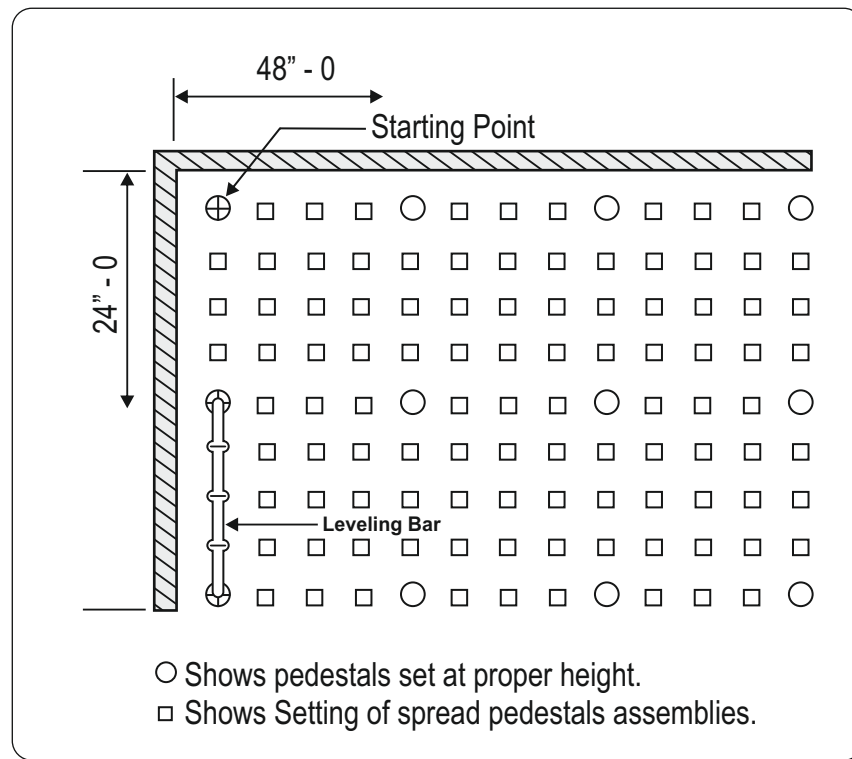

Figure 2

Using a laser or transit, shoot in a pedestal assembly to the proper FFH every 8 or 10 feet in both directions (depending on the length of your leveling bar.) By spanning two pedestals at proper FFH with the leveling bar, adjust all the pedestals in between to the bottom surface of the bar. As you adjust each pedestal assembly, center it on the two-foot marks permanently marked on the bar

Glue each pedestal base in the spread area to the sub-floor. Using a spatula type device, tilt up base plate without changing its location and apply adhesive to bottom of base plate. After laying pedestal accordingly to grid, stringer will snap on top of pedestal head, follow up by tightening the stringer with screw. Beginning again at the starting point, lay four rows of panels along the longest wall. Check to see that you are staying on control lines, and that panels do not rock.

Follow the same previous procedure for laying panels and be sure to follow the control lines. If you do not stay on the control lines, the floor will not be square and your grid lines will not be straight. After laying in the ELL (Sections of access floor laid along perpendicular control lines forming an 'L' shape, normally 5 panels wide) section, check and re-check to be sure it is square. When you are certain the ELL is square, continue to install rows until the ELL becomes a rectangle or square. While you are laying panels in this area, you should have someone spreading, shooting, leveling and preparing the next adjacent area for panels

T ^ & @ & # \$ % & ' () * + , - . / : ; < = > ? [\] ^ _ ` { | } ~ ¡ ¢ £ ¤ ¥ ¦ § ¨ © ª « ¬ ® ¯ ° ± ² ³ ´ µ ¶ · ¸ ¹ º » ¼ ½ ¾ ¿

À Á Â Ã Ä Å Æ Ç È É Ê Ë Ì Í Î Ï Ñ Ò Ó Ô Õ Ö × Ø Ù Ú Û Ü Ý Þ ß à á â ã ä å æ ç è é ê ë ì í î ï ð ñ ò ó ô õ ö ÷ ø ù ú û ü ý þ ÿ

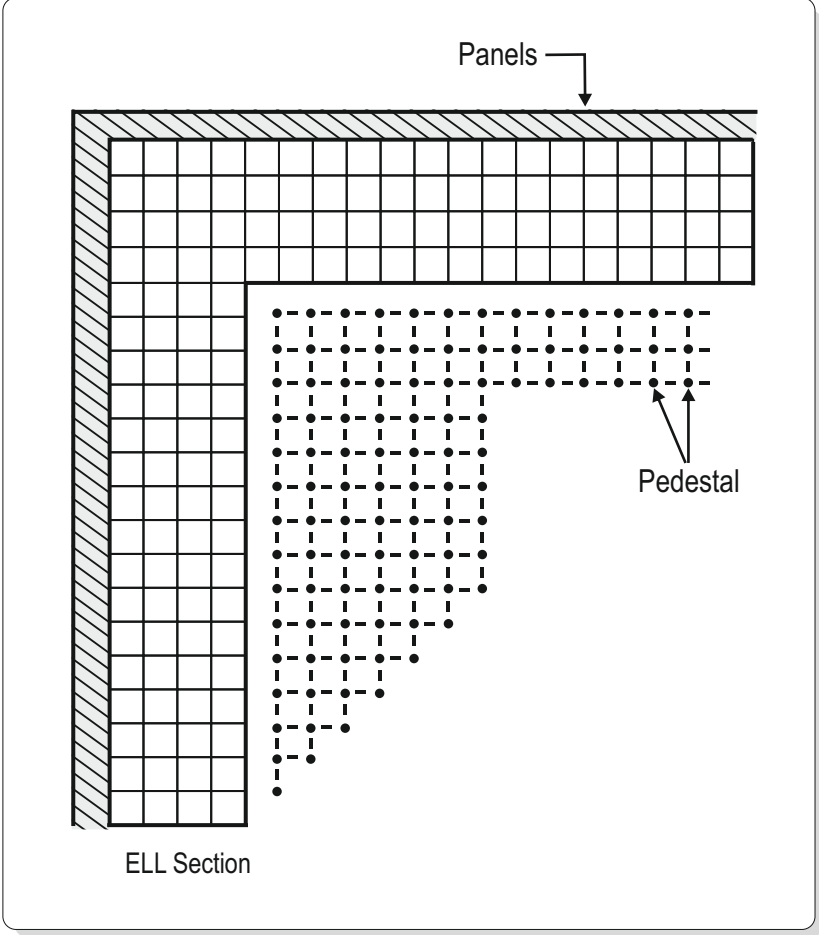

Figure 3

After the first section of a floor is installed, check to see that all the grid lines are straight. If the grid is not square, you can make them square by bumping the rows of installed panel with your foot. If this fails, take up every third or fourth row of panels and tap the bases in the direction of the panels that have to be moved. All grid lines should be straight before cutting in the perimeter panels.

Caution: Be sure not to create a tightness problem that will result in difficult removal and reinstallation of panels.

After installing the first section of raised flooring, only one chalked control line along the long wall needs to be used for the remaining of the floor. The initial section of floor normally dictates the squareness and location of the rest of the floor. However, it is possible in a long room to allow a curve to develop in small increments in the grid. Therefore, a dry line should be kept stretched along the short wall until at least a four-panel-wide section of the floor is installed the entire length of the room. In setting this dry line, secure one end at the starting point on the grid line between the first two panels. Raise the line about one inch off the panel, then stretch the line to the other end of the floor and do the same there. The line should not override the panel edges. If incorrectly selected or installed, raised floors will break and serious injury or property damage can result.

Perimeter cut panels

According to the installation layout and the relevant starting line, after laying the full size panels the missing panels have to be placed along the perimeter of the room and cut on site on measurement.

The size of the cut panels must not be less than 11 Åm to fit with the average dimension of the pedestals head and the cut side towards the wall has to be protected against the humidity by using a self-adhesive neoprene soft tape or better by bonding the standard panels plastic edge band with a thermo-fusible of polyurethane glue.

The cut panels can be installed in two ways:

- Gravity laid over an L-shaped metal angle frame fixed directly to the wall.
- Gravity laid over the pedestal glued onto the slab towards the wall

To check the exact size of the cut panel by measuring the distance between installed pane and the wall.

StringerBasedSystem

In Stringers system, additional pedestals and cut stringers assembly supports the cut tile area, if not using L-shaped support angle.

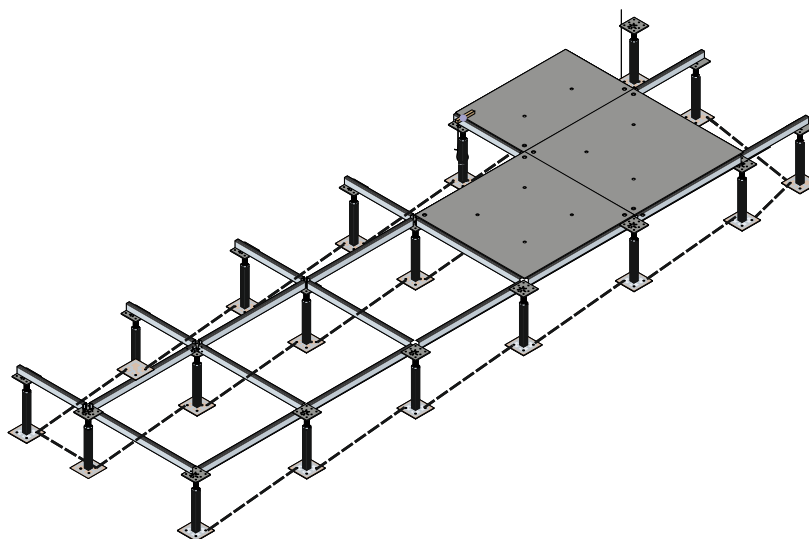

Alteration

The alteration of panel and pedestal parts (example cutting or making a hole) will lower the strength of parts, and need an additional pedestal for reinforcement.

General cleansing after Installation

Remove the largest elements and then vacuum the flooring thoroughly. The vacuum cleaner brush must be appropriate for the type of covering.

Moving heavy objects on the floor like furniture or equipment can generate excessive point loads. In order to avoid that situation, a trolley rolling on boards placed on the floor should be used.

The Guid To Use And Maintain Access Floor

1. Water is one of the biggest enemies of raised flooring. Excessive use of water on or under the flooring can make tiles swell at the edges.
2. Temperature and relative humidity should be controlled between 5~40°C and relative humidity 35%~75% in the room where raised access floor is installed.
3. The surface of access floor should be away from chemical products.
4. When cleaning the floor surface, do not use water directly on it, use a wet mop and squeeze out the water and mop on it.
5. The persons work in the computer room should wear soft bottom shoes.
6. We must use professional panel lifter to lift panel.
7. High pressure laminate tile requires little maintenance and can be easily cleaned by dry mopping and periodically damp mopping with mild detergent when necessary. Use of strong cleaning agents, waxing, bugging or refinishing is not needed. Under normal environmental conditions, do not clean floor surface with steel wool, nylon pads or abrasive of any kind, manually or with power equipment.
8. Do not clean with a mop saturated with oils or chemicals. A film on the floor will affect performance.

Water Spilling:

If water is spilled, the panels should be replaced and dried in order not to rust.

Taking off the Panel

Take particular notice of cabling and piping under floor cabling and piping and put the panel back with same orientation in its place. If an opening is left, surround the opening area by fence in order not to incur injury. If you use panel in high humidity condition, keep the room well ventilated in order not to create condensation and rust on panels.

Impact:

If heavy weight equipment is dropped or persons jump down onto the floor, it is possible that destruction or warping of parts may occur.

Adequate Ventilation:

There is a case in which dew condensation forms on a panel in rooms which no one uses or is exposed to high humidity. Dew condensation causes rust, earth leakage and similar, hence care should be taken to ensure ventilation in the room.

Wiring:

Wiring for equipment involves the risk of earth leakage. Consequently, easy wiring should be required.

Spares

It is recommended to have minimum spares available at the site for future maintenance (recommended 1.5% of installed components). Ensure to keep all on the spares in properly packed and sealed packing with item description mentioned on it for easy identification. Use a special area to keep spares to avoid damages during any other material movements.